



Z-Stuff for Trains

making model railroading more fun

Penfield, NY

drzander@aol.com

DZ-1010/1020/1030 Set Crossing Gates / Signals / WigWags With (2) DZ-1011 Block Signal Detectors

Rev 8-8-03

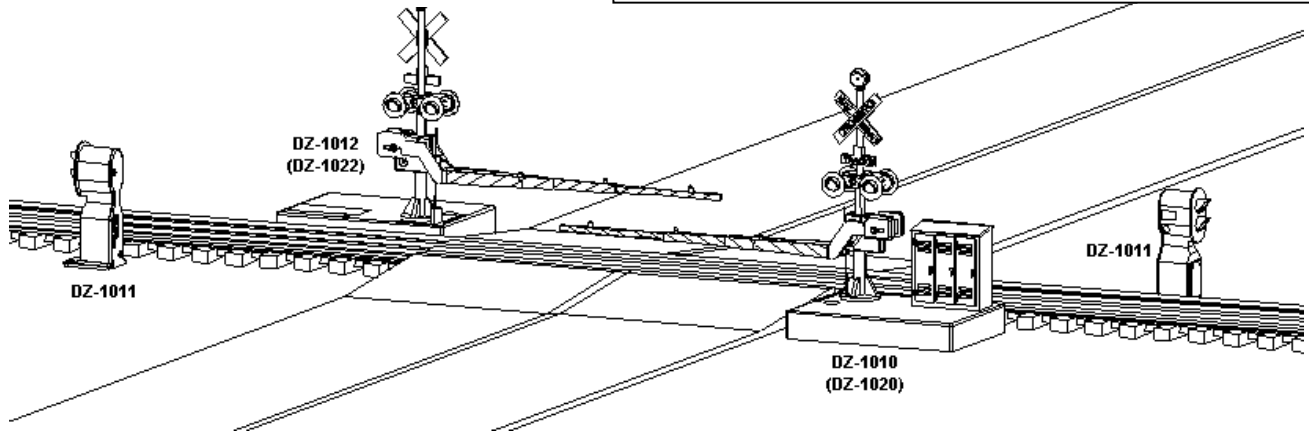

Crossing Gate Contents:

- Master** (1) DZ-1010 Crossing Gate w/sound
Slave (1) DZ-1012 Crossing Gate no sound

Crossing Signal Contents:

- (1) DZ-1020 Crossing Signal w/sound
(1) DZ-1022 Crossing Signal no sound

WigWag Signal Contents:

- (1) DZ-1030 WigWag Signal w/sound
(1) DZ-1032 WigWag Signal no sound

ALL include:

- (2) DZ-1011 Block Signal Detectors

Mounting screws for gates or signals & detectors and (5) Twist-on connectors

The Z-Stuff for Trains crossing gates, crossing signals and wigwags are unique, scale size crossing devices that include optical, infrared detection of passing trains to operate them. A digitally recorded crossing bell sound is also included. They do not require any connection to the track; however, they can be used with simple isolated rail control if desired. Each unit's control electronics has one HOLD input and two TRIGGER inputs. As long as the HOLD input is connected to COMMON the gates will stay down or continue to operate. Connecting a TRIGGER input to connect causes the signals to operate but they will stop after about 6 seconds unless a train enters the crossing. Up to (4) tracks may be accommodated at a crossing, although additional block signal detectors would be required.

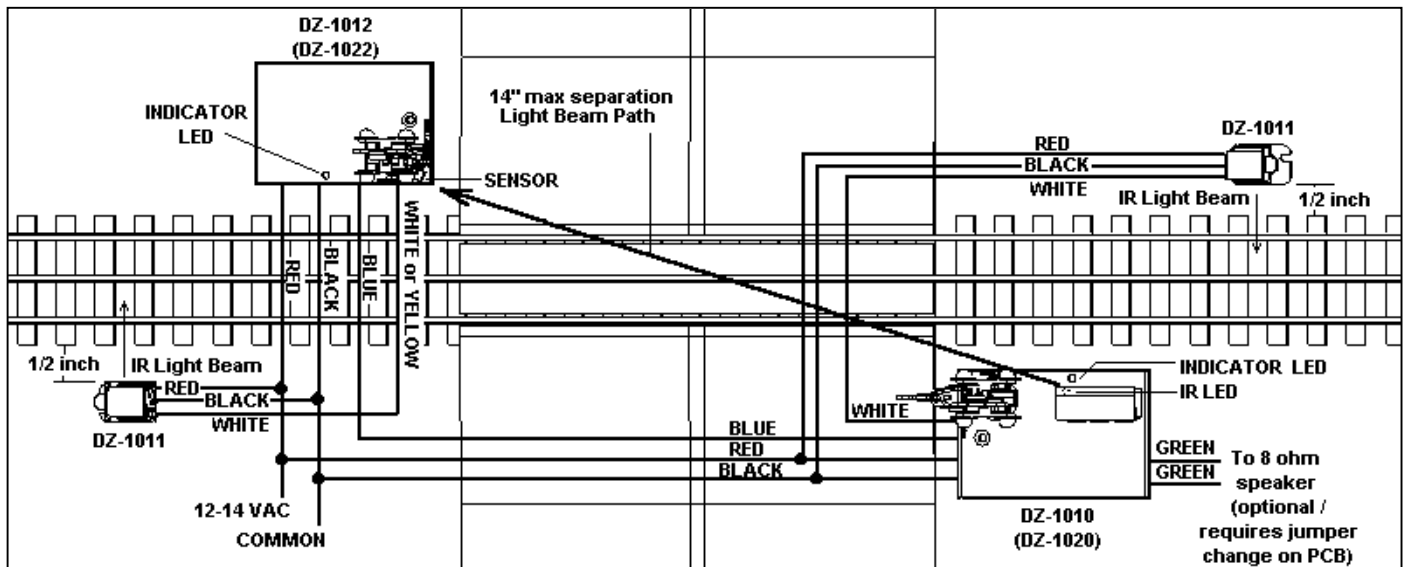
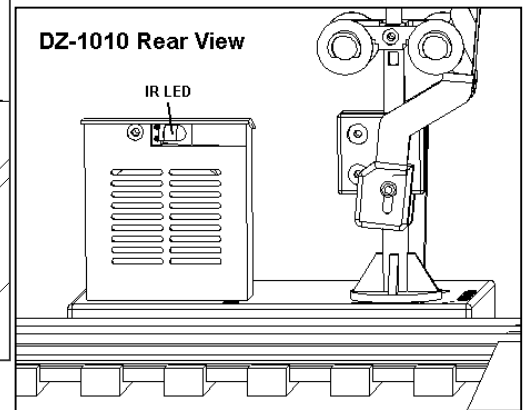
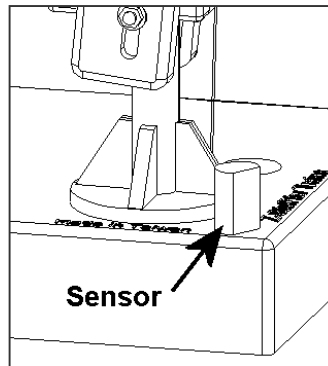

QUICK START - Testing Crossing Gates / Signals / WigWags

(Before installing Crossings Gates or Signals on your layout, test them on a table.)

1. Make sure power is OFF.
2. Connect the RED wires together and connect them to 12-14VAC (accessory power).
3. Connect the BLACK wires together and connect them to COMMON.
4. Connect the BLUE wires together.
5. Arrange Crossings as shown above.
6. Turn power ON.
7. Gates should go down with lights flashing while making a warning bell sound.
8. If crossings do not actuate, momentarily touch BLUE wires to BLACK wires to actuate.
9. Use RED Indicator LED in base to align the pair of crossings so IR LED points at SENSOR. When the IR LED and SENSOR are aligned, the RED Indicator LED will go out.
10. Be careful not to block the Light Beam Path from IR LED to SENSOR, as shown above.
11. When the Light Beam Path is momentarily blocked, the crossing will operate for a short period of time and then stop. If the Light Beam Path is continuously blocked the gates will stay down and the signal lights will continue to flash.
12. For Crossing Gates, adjust gate arm speed using switches on bottom.

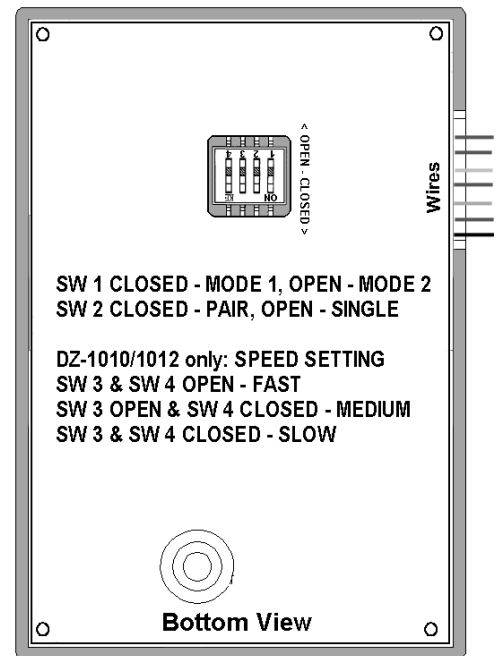
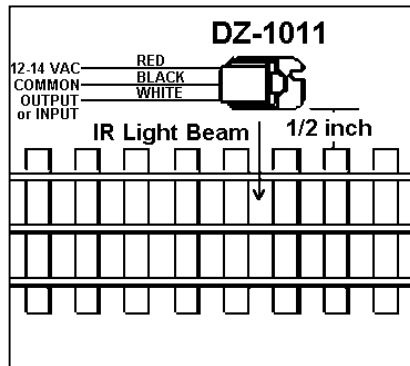
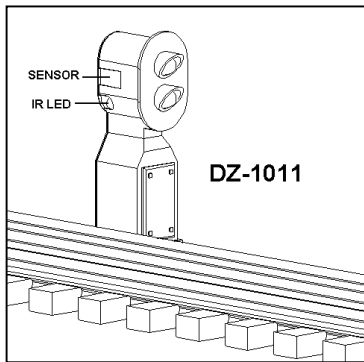

Testing with (2) DZ-1011 Block Signal Detectors

1. Turn power OFF.
2. Connect RED wires of both DZ-1011 to RED wires of Crossings.
3. Connect BLACK wires of both DZ-1011 to BLACK wires of Crossings.
4. Connect WHITE wires of both DZ-1011 to WHITE or YELLOW wire of one of the Crossings. It doesn't make any difference which one.
5. Turn power ON.
6. Position Block Signals so that the SENSOR on the Block Signal does not receive any reflected light from its IR LED. The GREEN LED should be lighted at this time.
7. Place your hand about 1 inch from the SENSOR on the side of the Block Signal. The GREEN LED should go out and the RED LED should light. This should also actuate the crossing gates / signals.
8. Check to make sure that when one Block Signal changes from GREEN to RED that the other Block Signal also changes. Having the two WHITE wires of the Block Signals connected together assures that they both change together.

You are now ready to install your Crossing Gates / Signals on your layout.

Options: (Note - switches are on the bottom of each unit.)

For the Crossing Gates, the operating speed of the gates may be adjusted from about 1 – 6 seconds by setting the adjustment switches on the bottom. The warning bell sound may be set to ring only while the gates are in motion (MODE 1), while in motion and while down (MODE 2), or no sound (GREEN WIRES connected together).

For Crossing Signals, the bell sounds continuously while the lights flash (Mode 1) or for only 2sec. of bell sound (MODE 2).

For WigWag Signals, the bell sounds continuously while signal swings (Mode 1) or for only 2 sec. of bell sound (Mode 2).

For Both Sets, an external, 2-3", 8-ohm speaker may be used to give an improved "clanging" sound. Connect the external speaker to the two GREEN wires.

For Use with Isolated Rails and/or without the optical detection, the jumper SW 2 should be in the OPEN position. This will also permit the devices to be used independently at separate locations if so desired.

Installation:

The wiring for the crossing gates and signals are shown in Table 1 and FIGURE 1. 12-14 VAC should be wired to the RED wires and Common to the BLACK wires.

TABLE 1			
DZ-1010 / DZ-1012 Crossing Gates DZ-1020 / DZ-1022 Crossing Signals DZ-1030 / DZ-1032) Wigwag Signals		DZ-1011 Block Signal Detector	
Wire Color	Function	Wire Color	Function
RED	12-14 VAC	RED	12-14 VAC
BLACK	COMMON	BLACK	COMMON
BLUE	HOLD INPUT	WHITE	OUTPUT or INPUT
WHITE	TRIGGER 1 INPUT		
YELLOW	TRIGGER 2 INPUT		
	DZ-1010-1020-1030 ONLY		
GREEN	EXTERNAL SPEAKER		
GREEN	EXTERNAL SPEAKER		

The **BLUE** wires of both crossing signals should be connected together. When power is applied, unless the two units have been positioned as shown below, the lights will start to flash, the units will operate and the bell will sound. This is because the light SENSOR on the DZ-1012 / 1022 / 1032 SLAVE needs to receive a signal from the IR LED on the DZ-1010 / 1020 / 1030 MASTER. The IR LED is on the back, top of the electrical box on the MASTER unit. If units are aligned as shown below, the RED indicator lights will go out after a 6-8 second delay, the signal lights will stop flashing and the gates will go up. Breaking the light beam from the IR LED to the SENSOR by your hand or a train car will trigger the units to operate. They will continue to operate as long as the beam is blocked. It is also possible to activate the units by connecting the **BLUE**, the **YELLOW** or the **WHITE** wires to **COMMON**. The DZ-1011 Block Signal Detectors operate this way. The **BLUE** wire will **HOLD** the gates down and cause the LED(s) to flash. The **YELLOW** and **WHITE** wires will only **TRIGGER** the operation and the LED(s) to flash, but after 6-8 seconds the operation will stop even if the wires remain connected to **COMMON**. This is so trains, which are detected but do not enter the crossing, will not cause the continuous operation of the signals.

The two units can be **separated by about 14 inches**.

DZ-1011 Installation:

The DZ-1011 Block Signal Detectors add a wonderful touch of realism to your layout and they provide early detection of trains approaching the crossing. You may place them as far up and down the tracks as you like. As shown above, they sense the passing train on only one side. Placing them about 1/2 inch from the edge of the track tie should provide reliable detection of all your engines and rolling stock.

The GREEN LED will switch to RED as the train passes and return to GREEN about 2-3 seconds after it is gone. The wire functions of the DZ-1011 are shown in TABLE 1. Connect the RED wire to 12-14VAC and the BLACK wire to COMMON. The WHITE wire should be connected to either the WHITE or YELLOW wires of the DZ-1010 or DZ-1012.

Since the DZ-1010 and DZ-1012 are connected together by the BLUE wires, it is only necessary to connect to one of the units. By connecting the two DZ-1011 WHITE wires together, when one changes, the other will also change to indicate that the track is occupied.

The Block Signal Detectors may also be used separately to detect trains or just as signals. If the WHITE wire is connected to COMMON, the GREEN LED will go out and the RED LED will light.

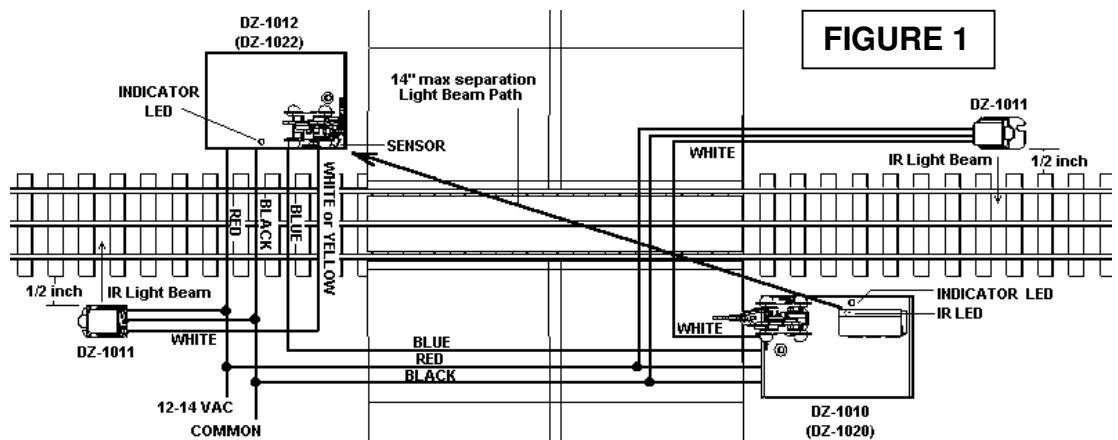

FIGURE 1

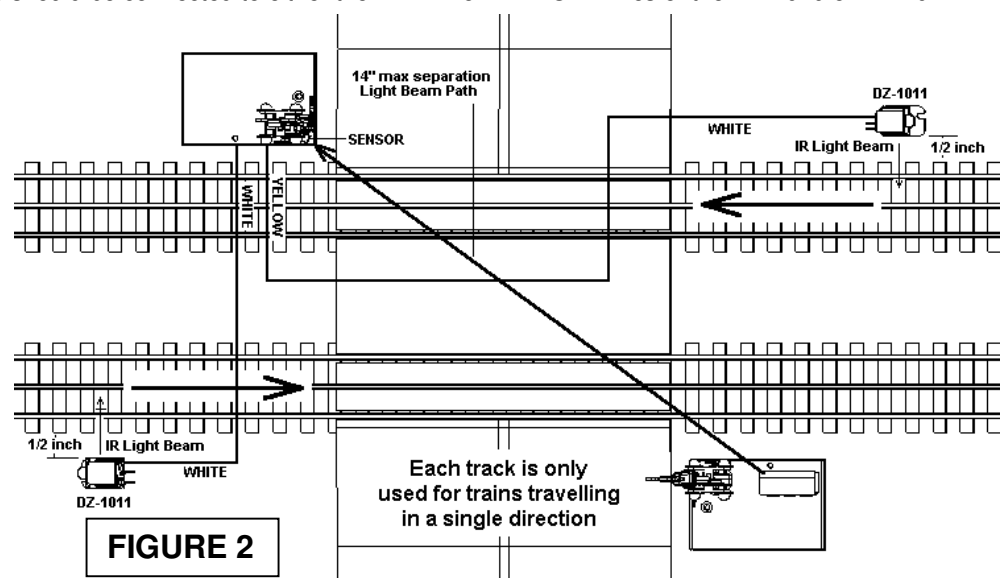

FIGURE 2

MULTIPLE Track Setups:

SINGLE DIRECTION TRACKS -The crossing signals may be used with multiple tracks. Usually this requires additional DZ-1011 Block Signals. However, if each track is only used for trains traveling in a single direction, then the two block signals provided may be used as shown in FIGURE 2. Each block signal is wired to it's own TRIGGER input. In this case, one is wired to the YELLOW input and one to the WHITE input.

BI-DIRECTIONAL TRACKS -

For the case where both tracks have trains that could be approaching the crossing from either direction, you will want to purchase additional DZ-1011 Block Signal Detectors and position them as shown in FIGURE 3. The wiring of the Crossing Gates / Signals is as before, but each pair of block signals is wired to one of the TRIGGER inputs. The block signals on TRACK 1 are wired to the WHITE TRIGGER input and the block signals on TRACK 2 are wired to the YELLOW TRIGGER input.

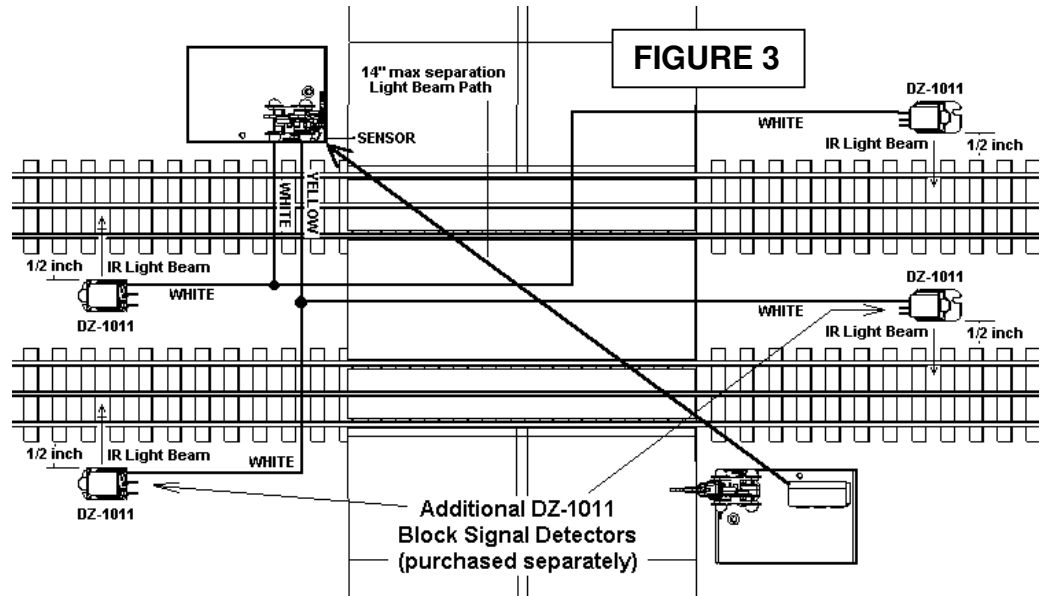

ISOLATED RAIL usage:

The crossing signals may be used with isolated COMMON rails to control the units. Be sure to connect the COMMON of the power of the crossing signals to the TRACK COMMON. The isolated rail is connected to the BLUE wire.

If a train is detected by the block signal and stops before it enters the crossing, after 6-8 seconds the operation would stop and not continue until the train breaks the light beam in the middle of the crossing. But, with the isolated rail, the operation would continue as soon as the train contacts the isolated rail.

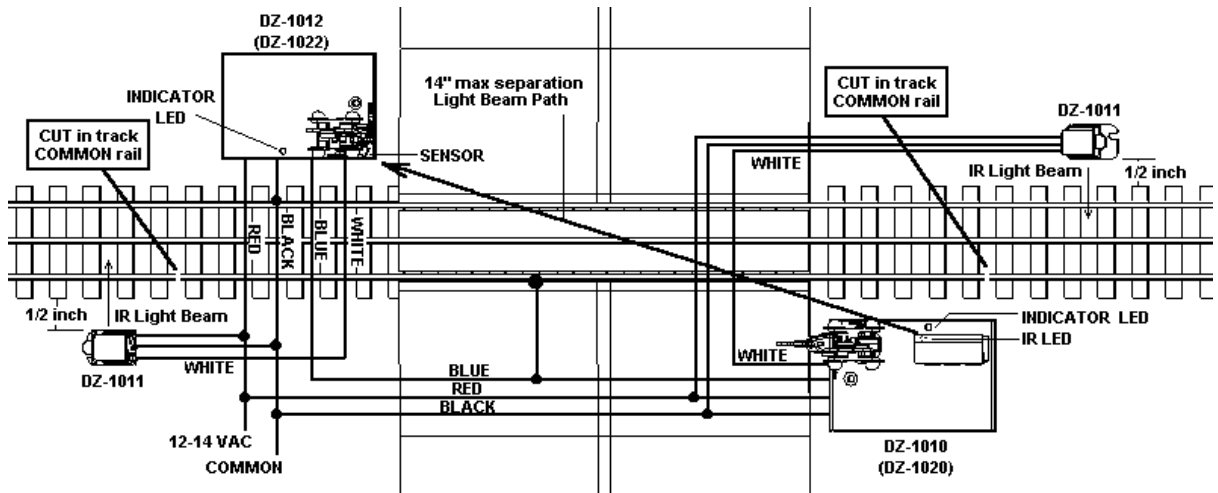

For Parts and Service Contact:
GarGraves Trackage Corp.
Ross Custom Switches

315-483-6577
860-886-6800

Z-Stuff for Trains

585-377-0925