



Z-Stuff for Trains

making model railroading more fun

Penfield, NY

drzander@aol.com

DZ-1240 Auto Reverse & Stop Module w/HORN option

Rev. 9-20-02

Contents:

- (1) DZ-1240 Controller
- Mounting screws for controller

Features:

All Engines or Trolleys must have an E-unit for this module to operate correctly as an auto reversing unit.

The DZ-1240 Auto Reverse and Stop System adds a little touch of realism to your layout. It provides auto reverse for a point to point run and can insert timed stops between end points or blow the horn or whistle on youi engine if it is equipped with one. The system will work with trolley or transit cars also. The System can be used with a point-to-point track or a loop of track. The system controller will stop the engine or trolley at each end point or inserted stop and then release it after a delay.

DZ-1240 Setup & Test:

See Figure 1 - Consider testing the setup on a bench or tabletop before installing on your layout.

- 1) Connect a short piece of wire (TEST WIRE) to COM of the power connector.
- 2) Connect 9-12VAC to the power input and turn power **ON**. (If you are using accessory power from your trolley power transformer, the common terminal should connect to the common of the transformer.)
- 3) The POWER LED should turn **ON**.
- 4) Take the TEST WIRE attached to COM and touch it to the 'EAST' pin of the Sensor Input connector. The Module will turn on the TRACK POWER LED several times, then after a short delay turn it on once.
- 5) Take the TEST WIRE attached to COM and touch it to the 'WEST' pin of the Sensor Input connector. The Module will turn on the TRACK POWER LED several times, then after a short delay turn it on once.
- 6) Now take the TEST WIRE attached to COM and touch it to 'MID' pin the Sensor Input. It will turn on the HORN LED for a short time.

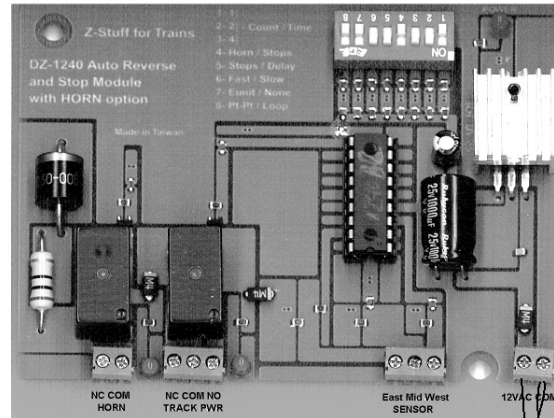

FIGURE 1



This completes the "Bench Testing" of the DZ-1240. Now you are ready for installation!

Installation:

Installation consists of making wire connections to the track and creating isolated outside rails when needed. You need to wire the controller as shown in Figures 2 for point-to-point or Figure 3 for a loop of track. For either case, only the end point sensor(s) are required. The MID point sensor(s) can be used for blowing the horn or whistle or for the location of stop locations, but the option of selecting the number of stops will eliminate the need for cutting the track to create the isolated rail sections.

- 1) Create sections of isolated rail as shown in Figure 2 or 3. They should be longer than the length of your engine or trolley. The EAST/WEST end sensors (isolated rails are shown) are necessary for point to point operation and the MID sensor is optional. With Lionel track isolated rail is difficult, because each metal tie connects the outside rails together. If you are using Lionel type track, you can by special sections of Lionel track that have one outside rail isolated.
- 2) Connect wires from the isolated rail sections to the sensor inputs as shown in Figure 2.
- 3) Place an engine or trolley on the track. (if your engine or trolley or transit car does not have electronic reverse, then you will need to use a loop of track.)
- 4) Turn controller power ON and track power ON.
- 5) The engine or trolley should be started if it is not all ready running, by cycling power (pressing the direction button).
- 6) The engine or trolley should now stop at the end points and the horn or whistle should sound at each mid point.

Module Set up: Track Options / Engine Options:

All options are determined by the positions of the switches shown in Figure 4. The default options are shown. To correctly stop and restart engines, especially those without reverse units, the module must be told the type of engine or trolley that you are using. Also, you need to set up the module for either point-to-point track or a loop of track.

SWITCH 8 indicates that you are using either a point-to-point or loop layout. ON-Loop / OFF-Pt-Pt

SWITCH 7 indicates that your engine or trolley either has or does not have an E-unit for reversing. OFF-Eunit / ON-no Eunit

SWITCH 6 indicates the response time of the engine. SHORT (fast) or LONG (slow) response time. OFF-SHORT / ON-LONG

SWITCH 5 sets the meaning of switches 1-3. OFF position for number of stops and ON position for the delay time at each stop.

OFF-STOPS / ON-DELAY (at each stop).

SWITCH 4 determines whether the MID sensor causes the engine's horn/whistle to blow or to stop at a MID sensor input. OFF-HORN / ON-STOPS.

SWITCHES 1-3 set the number of stops or the delay (x 5 Seconds) at each stop. The number will be the sum of the numbers set to the OFF position plus 1. So, switch 2 OFF plus switch 3 OFF is 1+(2)+(4)=(7)*5 a 35 second delay. The same is true for the number of stops to be put in between end points, if switch 5 is set for STOPS, except the number is not x 5.

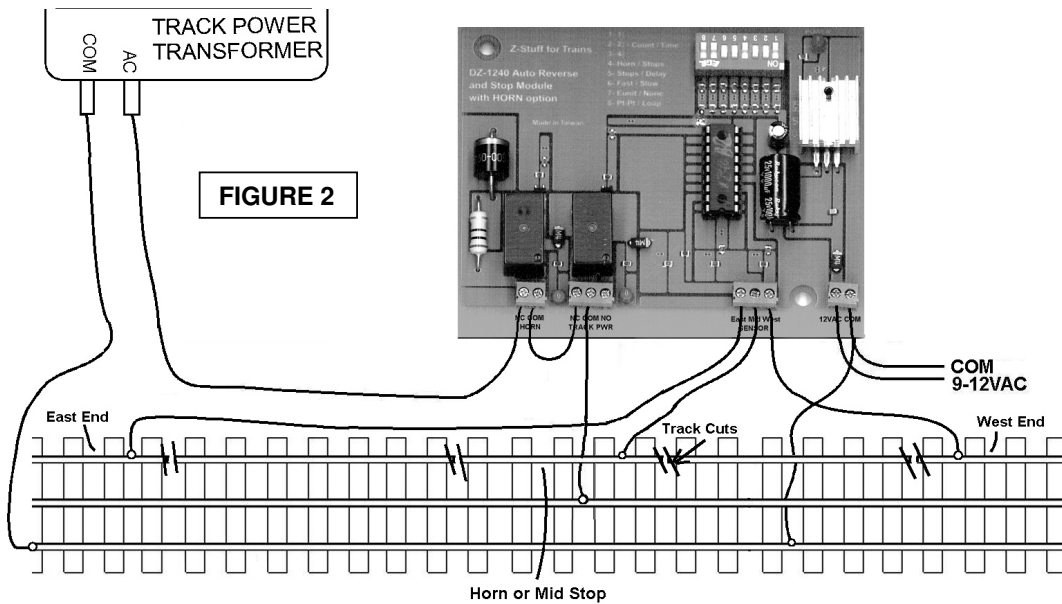

FIGURE 2

- OFF** **ON**
- 1- 1|
 - 2- 2| - Count/
 - 3- 4| Time
 - 4- Horn/Stops
 - 5- Stops/Delay
 - 6- Short/Long
 - 7- Eunit/None
 - 8- Pt-Pt/Loop

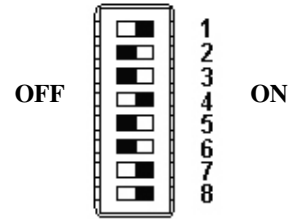

FIGURE 4

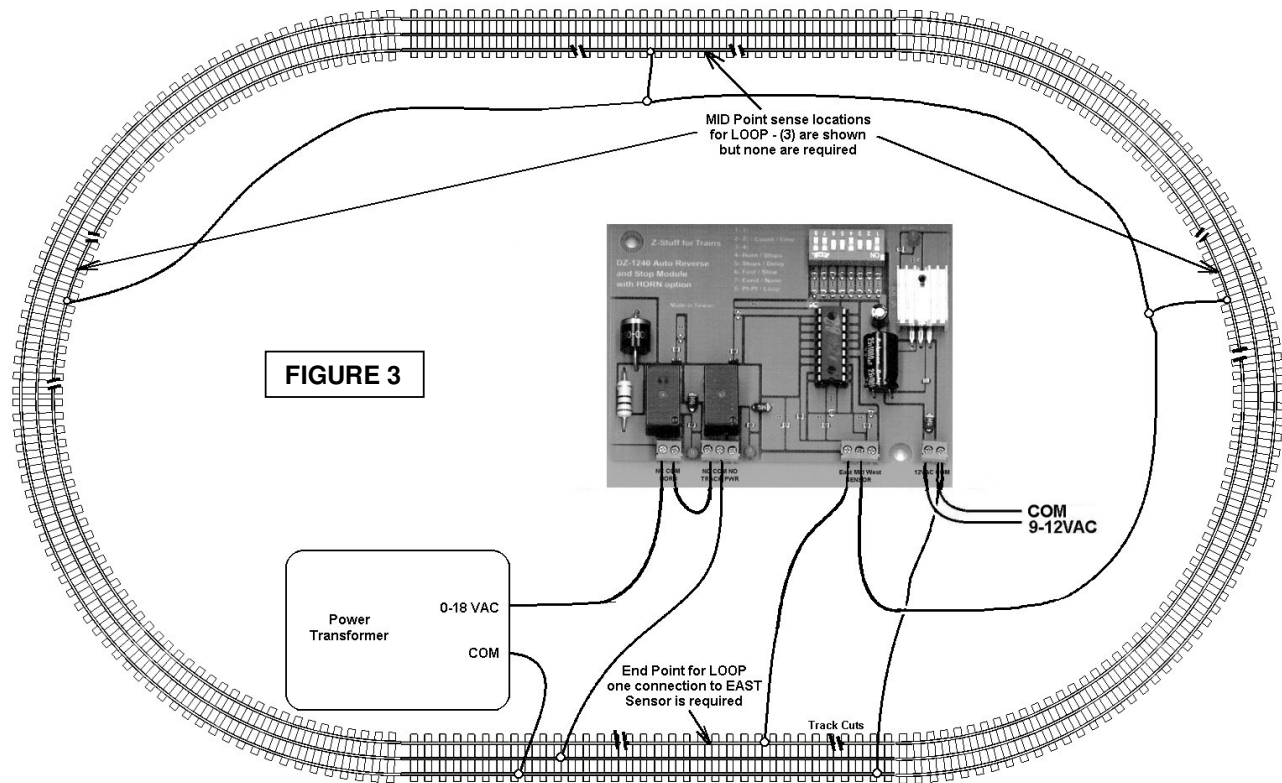

FIGURE 3

For Parts and Service Contact:

GarGraves Trackage Corp.
 8967 Ridge Road
 North Rose, NY 14516
 1-315-483-5677

or

Ross Custom Switches
 45 Church St.
 Norwich, Conn. 06360
 1-860-886-6800

Z-Stuff for Trains

Penfield, NY

z-stuff.net